



ROBUSCH®



Oil-free Screw Compressor & Screw Blower



Evolving
Technologies



In a competitive global market, our long history of supplying compressed air solutions that suit the customers' exacting requirements sets us apart from the rest.

Using modern machining systems and state-of-the-art production processes, our product range is constantly evolving. With a presence in over 50 countries we offer local service capability, ensuring our advanced technology is backed by technical support.

One of our latest product innovation is the new Robox Screw compressor unit the oil-free screw compressor package combines the features of the proven P.D. Blower Robox compact units with innovative components and design:

- **Efficient** thanks to its unique RSW patented rotors, which reduce the number of revolutions and enhance the capacity-pressure ratio
- **Silent** as a result of high-efficiency internal compression, silencers and a noise-reducing enclosure
- **Simple** installation and configuration
- **Flexible** to ensure the operation at the point of best efficiency
- **Oil free** for a more environmentally-friendly operation (Class 0 certification, according to ISO 8573-1)
- **Ease of maintenance** thanks to its simple and robust construction
- **Customised** with a wide range of options available



*Robuschi - the perfect partner
for your evolving needs.*



...the perfect solution for every application

Our team of highly skilled and experienced engineers is focused on developing products that offer maximum benefits to the customer.

With flexible configurations and enhanced technical features, the Robox Screw compressor package is the perfect solution for a broad range of environmental and industrial applications.

Read on to find out how Robuschi can make the difference in industrial applications.

Robox Screw
in pressure operation



One Package Two Technologies

(Frames 3.0, 3.5, 4.0)

Take advantages of the one solution for both lobe and screw blower technologies. Whether revamping plants, or your processes, you can review and compare each technology's benefits for your operation before you commit to buy. Either way you choose, the New Robox Lobe and Screw will fit your requirements.





Wastewater treatment

In wastewater treatment plants, energy consumption accounts for over 50% of annual costs. The Robox Screw range meets all cost reduction requirements, allowing customers to save between 15% and 30% on energy consumption when compared with other technologies.

Offering the maximum amount of air with minimum energy consumption thanks to its internal RSW compression, the Robox Screw is also extremely versatile in both continuous and 'stop and start' use. In addition, the ability to provide pressure levels of more than 1 bar (g) means the Robox Screw can feed tall collection tanks in wastewater applications - combining the best possible use of limited urban space with low levels of noise pollution.



Industrial WWT Plant: A worldwide gelatine manufacturer chose Robox Screw technology in its wastewater plants because of its advanced standards' compliance, reliability and high efficiency.

Municipal WWT Plant:
Robox Screw packages provide wide turndown capability, low noise and high energy efficiency.



Benefits at a glance

Aerobic activated sludge system for water treatment

- High efficiency
- Wide turndown capability
- Simple installation
- Reliable
- Silent
- Precise capacity fitting

SBR (Sequencing Batch Reactor) water treatment system

Nitrification - denitrification wastewater treatment in a single basin

- High efficiency
- Intermittent use
- Pressure variation with a constant capacity
- Simple installation
- Reliable

Silent Membrane water treatment system (MBR)

- High efficiency
- Intermittent use
- Pressure variation with a constant capacity
- Simple installation
- Reliable
- Silent



Industrial sector

In the industrial sector, the Robox Screw is used in a number of pneumatic transport processes, for transferring powders or granules of any type (plastics, flours, seeds, etc.) for fluidification and fermentation as well as in the conveyance of air and neutral gases.

The oil-free Robox Screw ensures low temperatures - 20% less than that of the other technologies - without any risk of deterioration and/or pollution of the material transported.

This is combined with outstanding reliability and improved efficiency when compared with more traditional technologies. By integrating the Robox Screw with the company's other technology options, Robuschi is able to provide a complete package for the industrial sector with pressure levels of up to 2,500 mbar (g).

Benefits at a glance

Pneumatic transport

- High efficiency
- Intermittent use
- Accurate flow rate setting
- Low temperature process
- Oil-free technology (Class 0 certification, according to ISO 8573-1)
- Wide range
- Highly reliable process thanks to low rotor rotation speeds (max. 6.000 rpm)
- ATEX 3 certification

Combustion air Cooling air

- High efficiency
- Precise capacity fitting
- Reliable

Cushion under keel air carpet in the shipyard industry

- High efficiency
- Reliable
- Wide pressure range

Air knives

- High efficiency
- Reliable
- Silent low pulse



One of the European leaders in the production of disposable plastic tableware and food containers, collaborating with leading international distribution chains too, replaced old vacuum technology with the Robox Screw in vacuum operation. The unit is working at 300 mbar(a) with a consistent energy savings (up to 30kW/h comparing to the previous technology).



One of the world's leading suppliers of cement and aggregates was impressed by the low speeds of the Robox Screw, and thanks to the new Robuschi package has solved its breakdown problems with screw machines. Before installing the Robox Screw, dust in the atmosphere would enter the previous screw unit, which, when combined with the high-speed operation of the compressor (causing high temperatures on the shaft sealing) would result in damages to the machine.



A famous pasta maker installed Robox Screw for flour and sugar pneumatic transport due to its lower temperature operation, lack of deterioration of the conveyed material and high energy performance.



The worldwide yeast producer relies on the Robuschi Robox Screw for the fluidisation air for its yeast fermenter.



The customer decided to install Robox Screw in order to provide a curtain of air bubbles to prevent floating and submerged objects from entering the docking area. They are impressed by the unit's robustness and heavy-duty capabilities.

Limitless industries

We are able to offer the best solution in diverse areas and sectors

- **Cement**
- **Petrochemical**
- **Iron Industry**
- **Tanning Industry**
- **Energy**
- **Wood**
- **Paints**
- **Shipyards**
- **Chemical/Pharmaceutical**
- **Food**
- **Plastics**
- **Textiles**
- **Glas Industry**
- **Ceramics**
- **Pulp & paper**
- **Renewable Energy**

Key Features

Robox Screw is available with a wide range of options to meet the needs of even the most demanding customers.

Low life cycle costs

The expense of a blower ownership is comprised of equipment, installation, energy, and maintenance costs. Equipment and installation are a one-time expense, while energy and maintenance are continuous costs of ownership. Robox Screw ensures a high level of efficiency (> 75%) within a wide compressor rotation speed range reducing energy consumption. In addition thanks to its robust construction and use of minimum parts contribute to high reliability and long intervals between maintenance.

Flexible

The RSW screw compressor offers a turndown capability in flow to meet the needs of the customer. It's also suitable for intermittent use with frequent stops and restarts to best satisfy the specific process requirements. The belt drive ensures the right capacity for the application, and also allows the installation of the motor most suitable for the power absorbed by the compressor (therefore operating at optimum efficiency).

Quiet operation

The optimum efficiency of the internal compression, guaranteed by the innovative Robuschi rotor profile, means less noise during the compression phase. The low rotor rotation speed (max. 6,000 rpm) and the absence of a step-up gear, along with special silencers and a noise-reducing enclosure (also available without sound hood - WL version), guarantee low noise levels from the compressor, thus allowing installation in a variety of applications.





Robox Screw

Extremely efficient oil-free compressor unit, in two versions: up to 1,000 mbar (g) with a maximum capacity of 10,100 m³/h and up to 2,500 mbar (g) with a maximum capacity of 9,400 m³/h.

Easy installation and maintenance

As it can be transported with a forklift and/or pallet truck, the Robox Screw offers easy installation. The electrical system connection is also simple, using the rear auxiliaries' cabinet for configuration with controller.

Furthermore, maintenance costs are reduced as every component of the Robox Screw has a simple and robust construction, thereby guaranteeing a long working life.

Thanks to the simple layout of the unit components, all routine maintenance tasks can be carried out from the front of the compressor, ensuring:

- easy oil change
- easy oil filter replacement
- easy oil pressure adjustment and air filter replacement
- easy drive belt replacement

Reliable

The painstaking design and meticulous choice of each component of the compressor, together with a low operating speed, make the Robox Screw extremely reliable. At the same time, the controllers ensure optimum machine operation via the continuous monitoring of the operating parameters. The functions of remote diagnostics and predictive maintenance are proven to contribute to reducing downtime.

Tailor made

The design of the Robox Screw can be tailored in order to meet customer needs and match the application requirements.



New Robox Screw for a Superior Package!

Premium Efficiency Air Ends

The air ends used here are from the CDL state-of-the-art, patented screw blower with 3x5 profile rotors designed with wide-diameter shafts to reduce the deformation caused by internal and external loads, thereby ensuring the blower can work efficiently in even the harshest conditions.

Unique Design

Thanks to its exclusive features Robox Screw has compact dimensions with the possibility of side-by-side installation. They are extremely easy to be installed with no requirement for ducting, so the compressor rooms can be kept to the minimum size.

Low Noise

Low noise emissions are ensured by our new discharge and suction silencer design. In addition, cabin enhancements grant noise reduction thanks to the special sound proofing material, upgraded panel thickness and enclosure air inlet and outlet ducts muzzled with a lined single-chamber plenum and lined bends.

Easy Installation

Save time and money thanks to the easy and simple installation of the Robox with ease utilizing the rigid base's dedicated channels for forklifts, and place it on any even surface, with no need for special foundations. Thanks to its compact design, the Robox can be quickly and easily integrated into your existing system.

Accessible Service and Maintenance

The design of this New Robox package ensures that the service points are easily accessible. To help you see inside, the enclosure side doors are hinged and removable. In addition, oil level can be checked while the Robox is running from the outside.

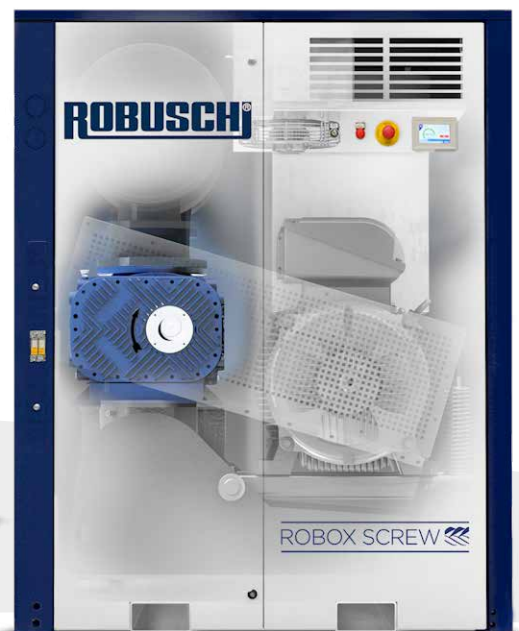

Options

ROBOX

CONNECT

download catalogue
Robox Connect



Leading-edge Robox Connect Controller

The touch screen controller is very user friendly with an intuitive menu. It provides you with a real-time view of the Robox Screw's operation, and allows you to continuously monitor the device. This ensures you spot problems and malfunctions before they happen thereby protecting your investment.

The controller manages a variety of operating functions available from the built-in screen, as well as remotely. You can monitor and configure each measured parameter and alarm from any display using a remote connection.

Main Robox Connect Controller Functions

- Multiple language configuration
- 44 analog and digital inputs / outputs
- Sequencing mode (multi-blower control)
- Interval maintenance with a dedicated P&I chart
- Parameter data transmission via Field Bus
- Parameter trends
- Alarms detections
- Data logger for service troubleshooting
- Suitable for any kind of starter device

What Are The Controlled Parameters?

- Suction pressure (P1)
- Discharge pressure (P2)
- Oil injection pressure (P3) (only for Robox Screw > 1,000 mbar(g))
- Noise enclosure temperature (T1)
- Discharge temperature (T2)
- Oil sump temperature driven side/oil injection temperature (T3)
- Oil sump temperature gears side/tank oil temperature (T4)
- Airend shaft speed indicator
- Oil level gear/driven side (*optional*) (L3 - L4)
- Main motor PTC
- Emergency stop kit (*optional*)



The Controller is compatible with iConn, the Industry 4.0 solution.

iConn
INDUSTRY 4.0

Robox Screw package Plug&Play version



It is possible to select different Robox Blower package configurations, according to customers' requirements.

The unit can be equipped with a main power electric cabinet:

- Star/delta starter
- Soft starter
- Premium frequency converter for maximum performance and reliability
- Electrical cabinet with IP54 protection degree and a forced cooling system
- Modular installation close to Robox unit or in an other location via wired connection for maximum flexibility
- Programmed control panel for process optimization and regulation
- Industry 4.0 solution with data transmission through the most popular communication protocols (Modbus, Profibus-Profinet, Canopen)
- Preset frequency converter on delivery for peace of mind
- Additional system for continuous monitoring of main parameters (*optional*)

Air Map

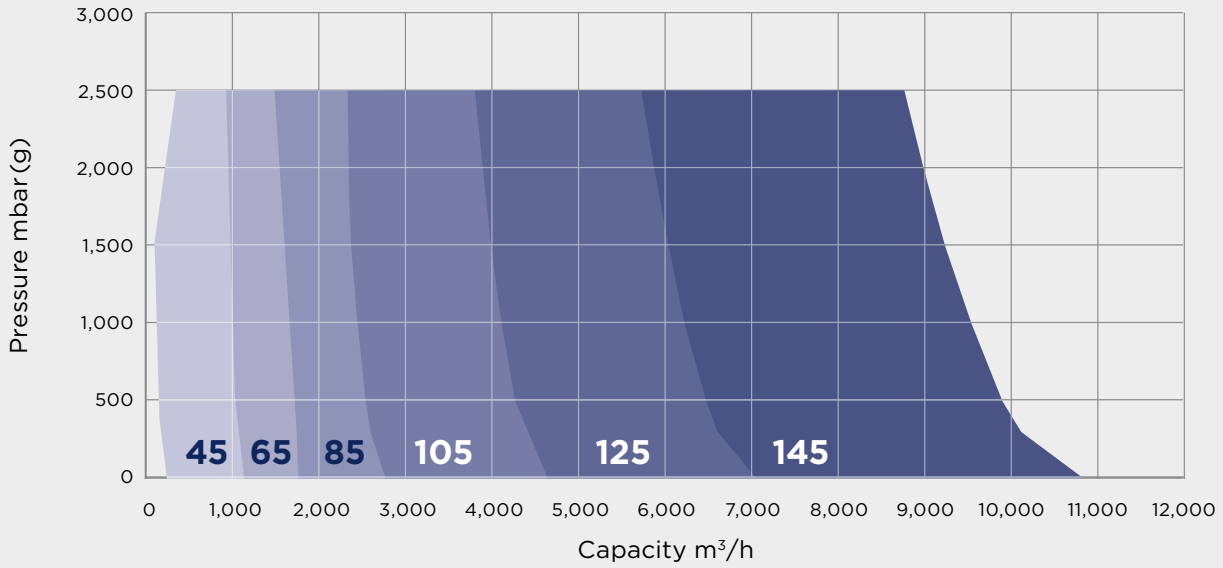

Robox Screw dimensions and weights - 2,500 mbar(g)

2 ROBOX SCREW

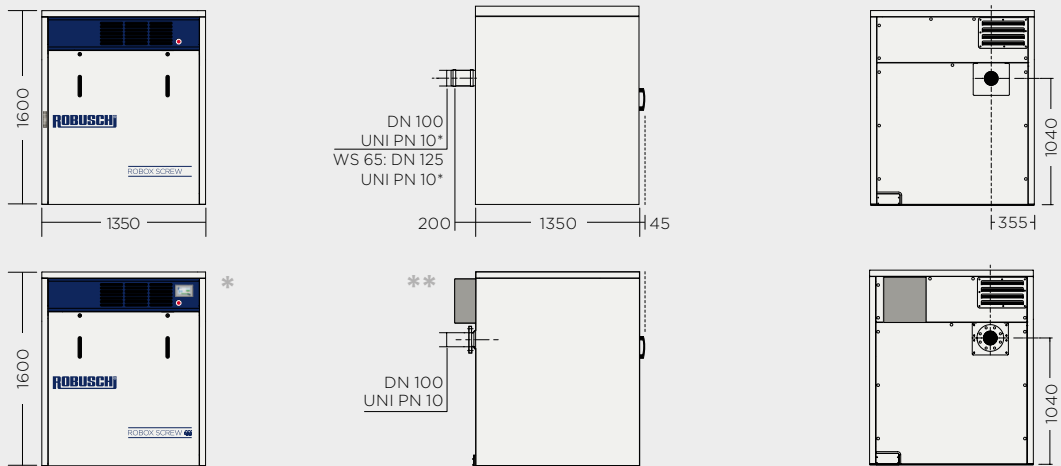

3 ROBOX SCREW

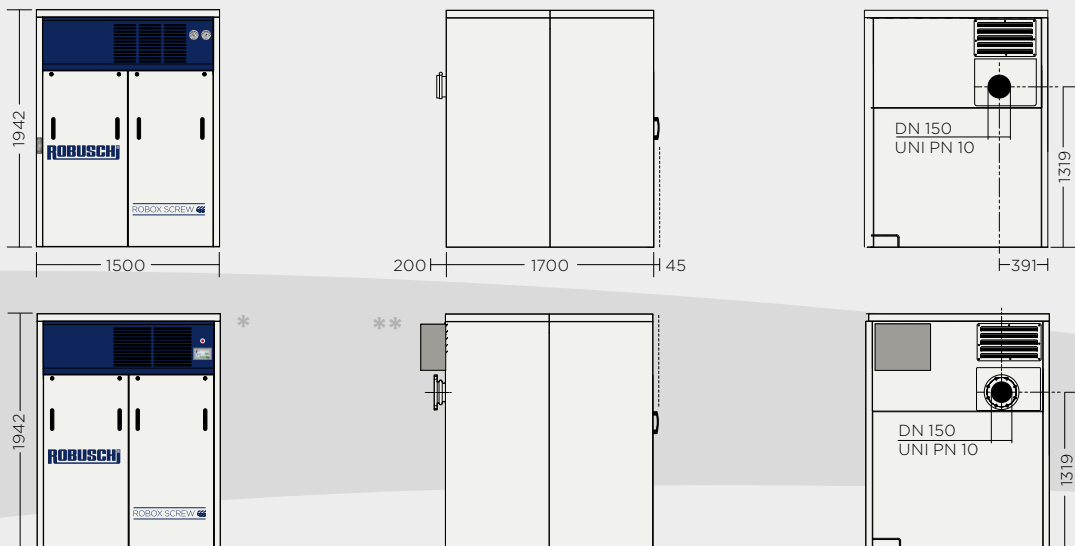

Robox Screw dimensions and weights - 2,500 mbar(g)

4

ROBUSCH
SCREW

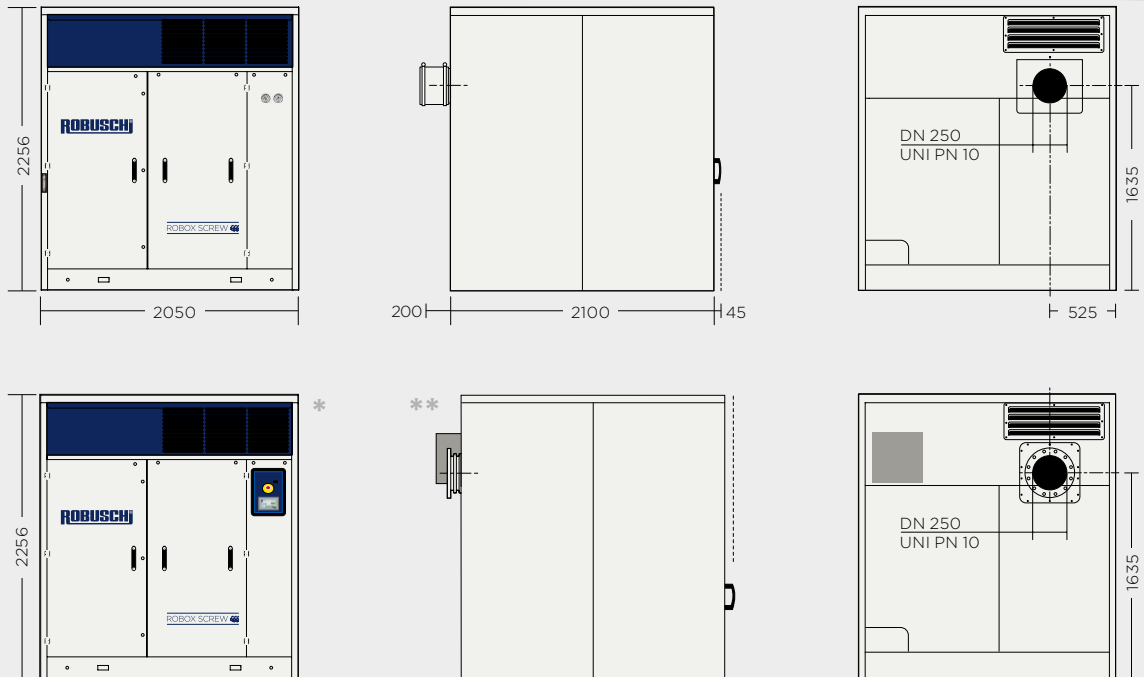

5

ROBUSCH
SCREW

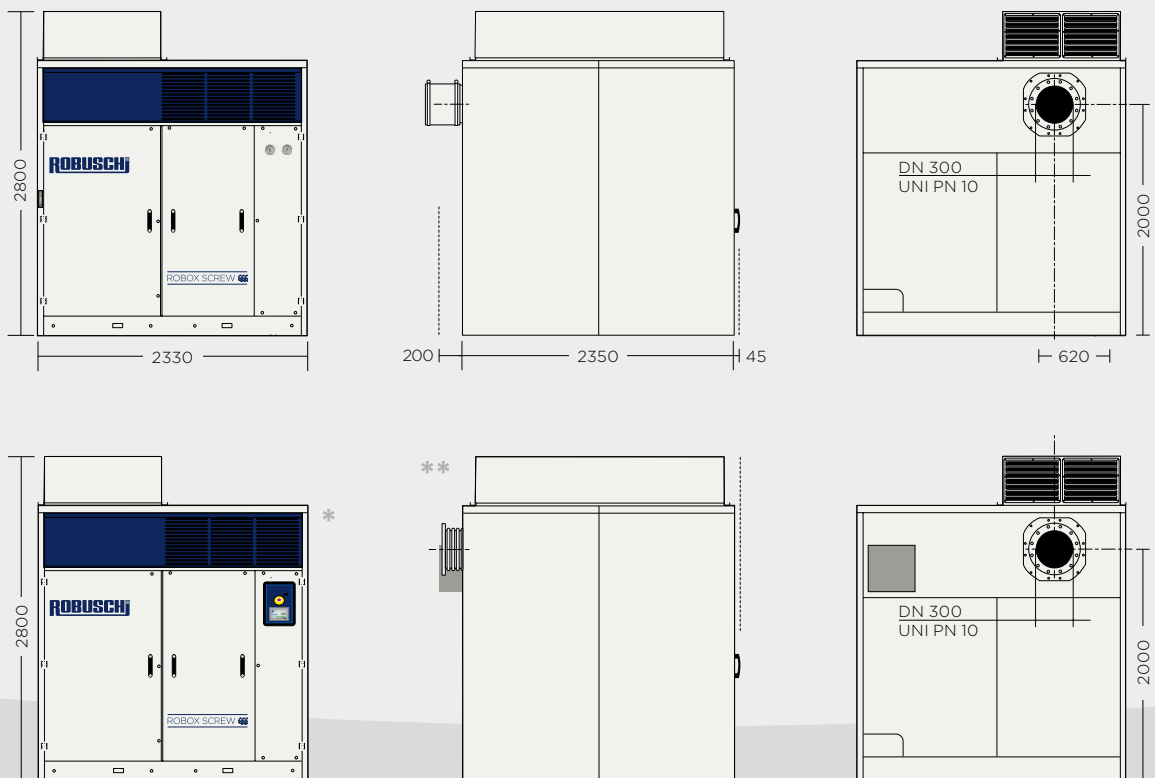

* Controller optional

** Only with controller

Robox Screw dimensions and weights - 1,000 mbar(g)

3.0 NEW ROBOSCH SCREW

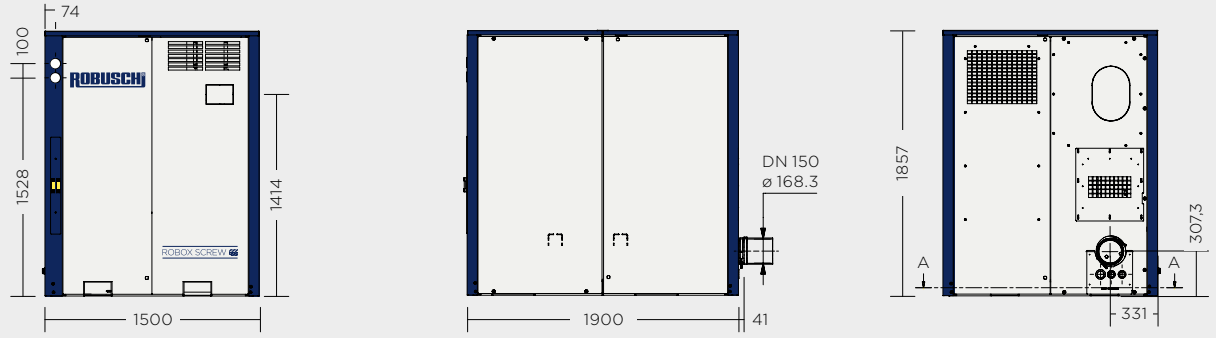

3.5 ROBOSCH SCREW

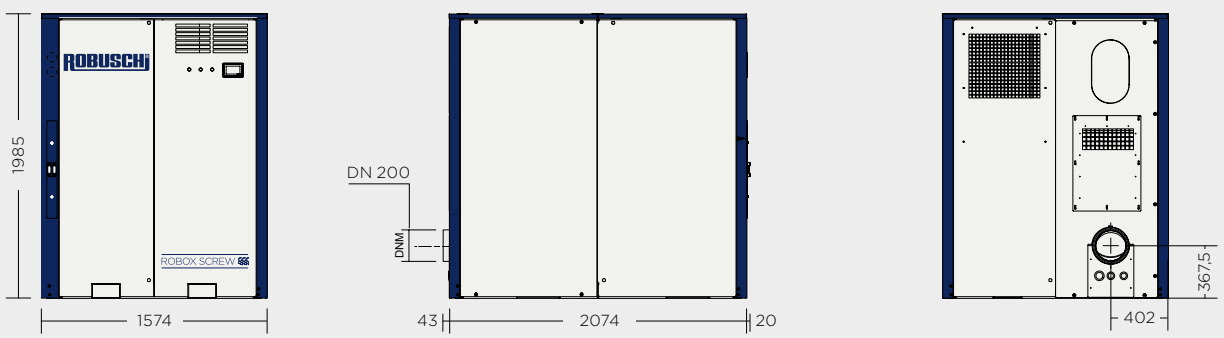

4.0 ROBOSCH SCREW

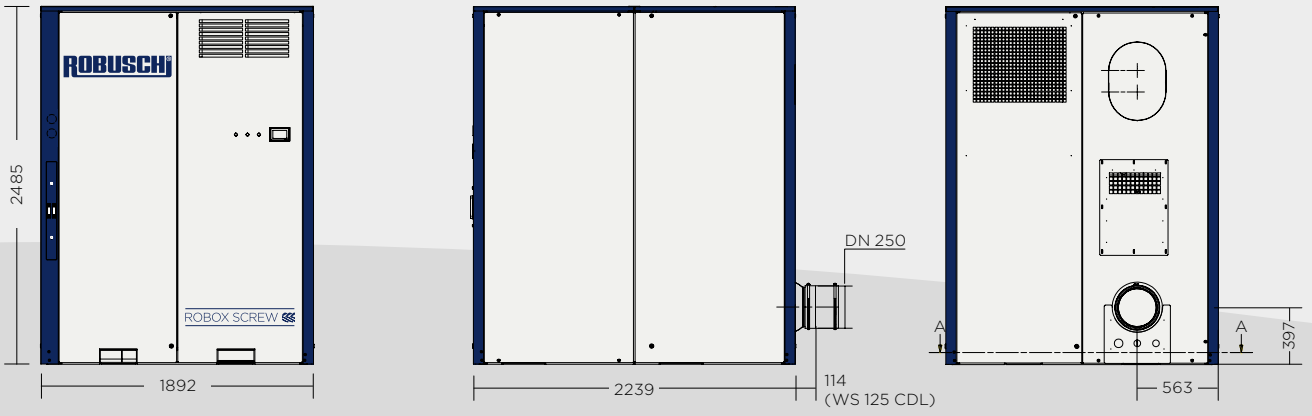

Robox Screw		Up to 1 bar(g)		Up to 2.5 bar(g)	
Frame	Airend Size	WL kg ⁽¹⁾	WS kg ⁽¹⁾	WL kg ⁽¹⁾	WS kg ⁽¹⁾
2	RSW 45	490	580	530	620
	RSW 65	530	620	570	660
3	RSW 65	-	-	840	1,050
	RSW 85	-	-	950	1,155
4	RSW 105	-	-	1,210	1,900
	RSW 125	-	-	1,600	2,285
5	RSW 125	2,790	3,565	2,850	3,625
	RSW 145	3,530	4,305	3,590	4,365
3.0	CDL 85	623	1,154	-	
3.5	CDL 105	984	1,580		
4.0	CDL 125	1,800	2,360		

(1) Without motor

Performances

Robox Screw WS - WL		PRESSURE			
		Up to 1 bar(g)		Up to 2.5 bar(g)	
Frame	Airend Size	Capacity m ³ /h	Max Motor Power kW	Capacity m ³ /h	Max Motor Power kW
2	RSW 45	1,050	37	980	75
	RSW 65	1,680	55	1,150	75
3	RSW 65	-	-	1,550	110
	RSW 85	-	-	2,400	132
4	RSW 105	-	-	4,060	315
	RSW 125	-	-	4,900	315
5	RSW 125	-	-	6,100	400 ⁽²⁾
	RSW 145	10,100	315	9,400	600 ⁽²⁾
3.0	CDL 85	2,650	90	-	-
3.5	CDL 105	4,300	160	-	-
4.0	CDL 125	5,776	200	-	-

(2) Version with direct coupling



Maximum uptime. Extending performance.

We provide a range of services to ensure our customers' machines are well maintained to deliver maximum performance.

We offer preventative and planned maintenance programs, genuine parts, on-site service, professional maintenance and efficient training.

Within our service portfolio, you will find many and varied options and services needed to get optimal performance, maximum uptime and operating efficiency from your Robuschi equipment.



Find your Genuine Parts at



**GENUINE
PARTS**

Scan the QR code

GARDNER DENVER S.r.l. Divisione ROBUSCHI Manufacturing facilities

Via S. Leonardo, 71/A
43122 Parma - Italy

GARDNER DENVER NEDERLAND B.V.

Barwoutswaarder 3
3449 Woerden
Netherlands

GARDNER DENVER Ltd. United Kingdom

Claybrook Drive,
Washford Industrial Estate
Redditch, B98 ODS
UK

INGERSOLL RAND Schweiz AG

Langfeldstrasse 90
CH - 8500 Frauenfeld
Switzerland

GARDNER DENVER Schopfheim GmbH

Johann-Sutter-Straße 6+8
79650 -Schopfheim
Germany

GARDNER DENVER S.A.S. Division produits industriels

70 avenue Albert Einstein
Zone du Château d'Eau
B.P. 50061 - F-77551
Moissy Cramayel Cedex
France

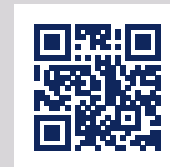

www.robuschi.com